

Important: If you are not a trained motorcycle mechanic, stop now. Ask a motorcycle shop to do the work for you.

The position of the handlebar will change by the offset. Please make sure, that all Bowden-cables and lines offers free wheel and no tension.

1. Make sure, that the handlebar has got sufficient clearance to the fuel tank.
2. All lines/cables must have the necessary length.
3. Secure all lines/cables against bending, twisting or squashing.
4. The bending radius of hoses has to be above 40mm. Hoses may not twist when suspension is working or fork is moved across the steering angle.
5. If necessary use longer/shorter brake- and clutch-lines, according to the FMVSS 106 standard.

After the fitment, please control all bolted connections!

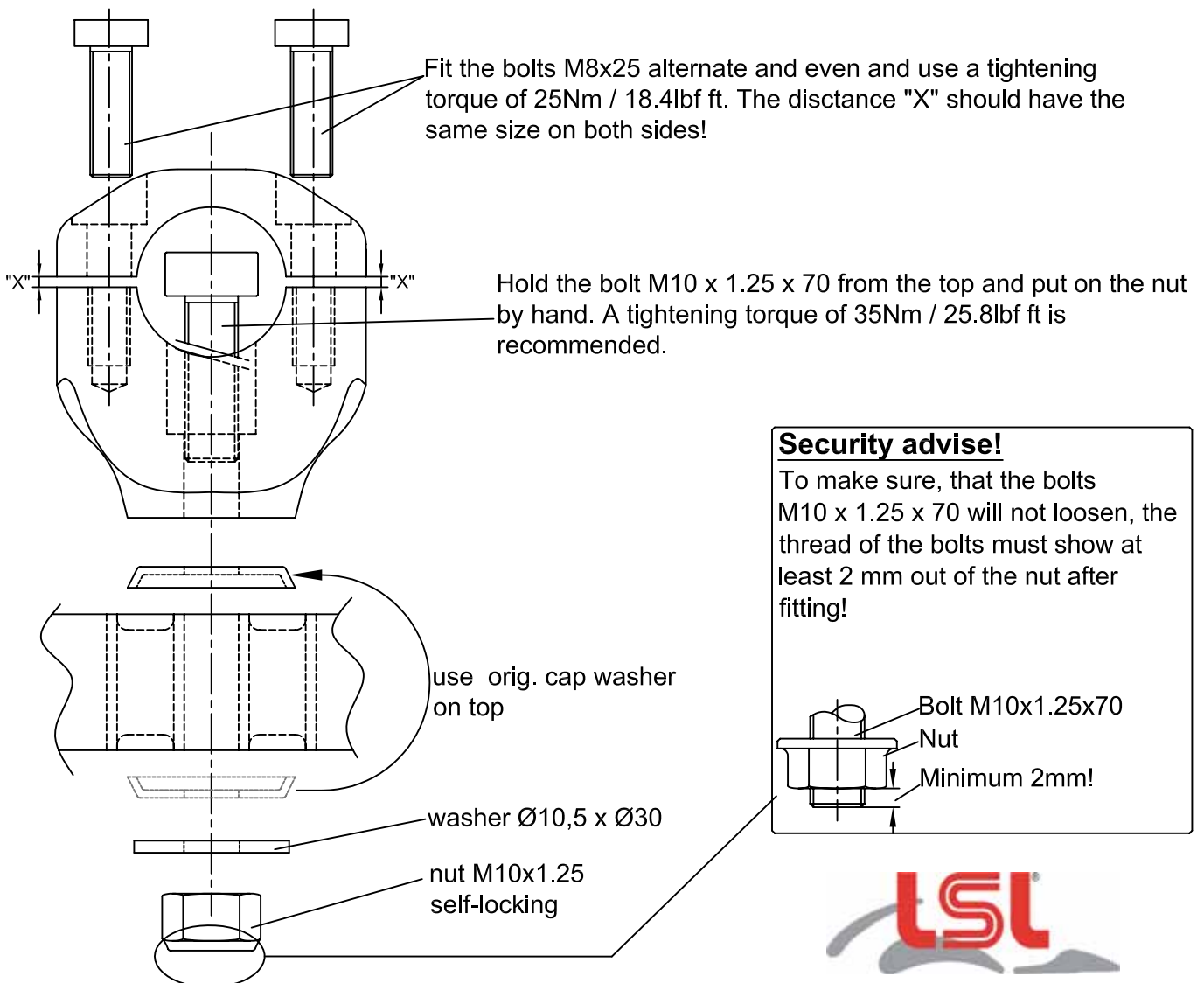

LSL-Motorradtechnik GmbH • D-47809 Krefeld

www.lsl.eu